

C2C CUBE 212

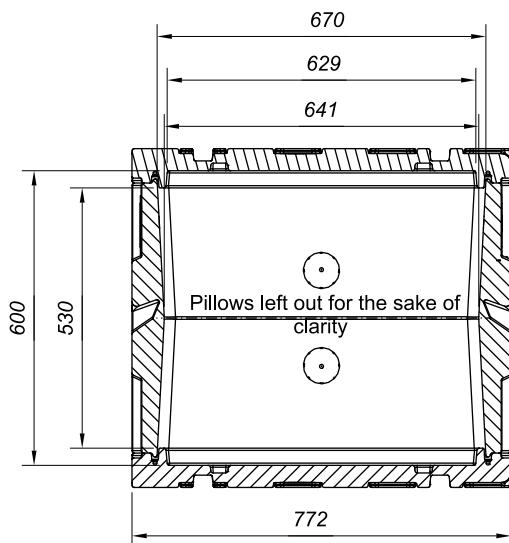

C2C Cube

Connecting cleanrooms.

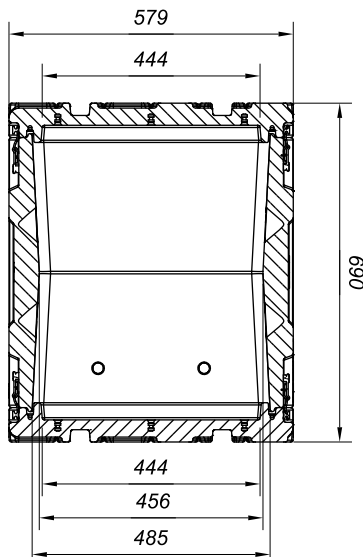

Cube specifications

Item number	4022.474.9970
Materials used	PELD, Fluorelastomer, Stainless steel
	<ul style="list-style-type: none"> • ISO class 5 • Tested and released according to ISTA & GID • Equipped with RFID tags • Cleanable label surface • Fastening holes inside • Hoisting belts and straps inside CE certified • Pillows of cleanroom fabric filled with LRPU foam • This model has 3 parts (bottom, sleeve, lid)

External dimensions 772 x 579 x 690 mm

Internal dimensions 629 x 444 x 600 mm

Net weight 30 kg

Content specifications

Max sensitivity	25 G on product
Target size product	500 x 300 x 300 mm
Max part size	575 x 390 x 340 mm
Pillow size	635 x 460 x 195 mm
Max part weight	50 kg*

Transport packaging

	<ul style="list-style-type: none"> • Cube packed in double antistatic LDPE bags • Hoisting belts around the cube • Packed cube inside corrugated carton • Corrugated carton on a pallet
--	---

Total weight 36 kg

Transport size 800 x 600 x 710 mm**

*Higher weights possible at different G **Without pallet