

C2C CUBE 223



C2C Cube

Connecting cleanrooms.

C2C CUBE | 223

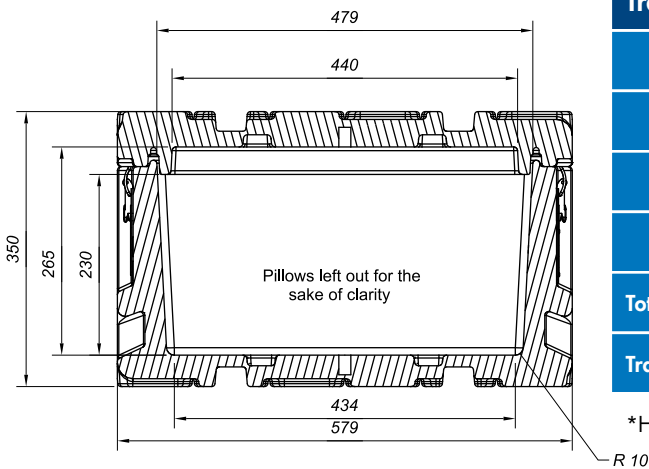
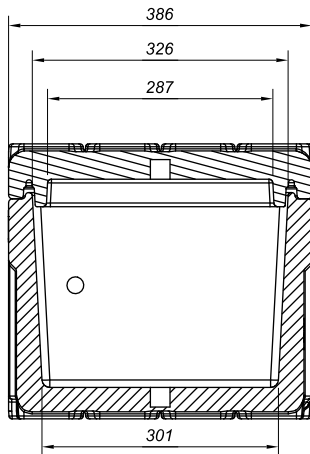

Cube specifications

Item number	4022.474.9950
Materials used	PELD, Fluorelastomer, Stainless steel
	<ul style="list-style-type: none"> • ISO class 5 • Tested and released according to ISTA & GID • Equipped with RFID tags • Cleanable label surface • Fastening holes inside • Hoisting belts and straps inside CE certified • Pillows of cleanroom fabric filled with LRPU foam
External dimensions	579 x 386 x 350 mm
Internal dimensions	440 x 287 x 265 mm
Net weight	7 kg

Content specifications

Max sensitivity	40 G on product
Target size product	350 x 200 x 120 mm
Max part size	400 x 245 x 160 mm
Pillow size	445 x 285 x 80 mm
Max part weight	10 kg*

Transport packaging

	<ul style="list-style-type: none"> • Cube packed in double antistatic LDPE bags • Hoisting belts around the cube • Packed cube inside corrugated carton • Corrugated carton on a pallet
Total weight	9 kg
Transport size	600 x 400 x 380 mm

*Higher weights possible at different G

NEFAB

Nefab Engineering Center
 Ekkersrijt 4126, NL-5692 DC Son
 C2C@NEFAB.NET | WWW.C2C-CUBE.COM